



BioMedical Admissions Test

4500/12

Wednesday 30 October 2019

30 minutes

SECTION 2

Scientific Knowledge and Applications

INSTRUCTIONS TO CANDIDATES

Please read this page carefully, but do not open the question paper until you are told that you may do so.

This paper is Section 2 of 3. Your supervisor will collect this question paper and answer sheet before giving out Section 3.

A separate answer sheet is provided for this section. Please check you have one. You also require a soft pencil and an eraser.

Please complete the answer sheet with your:

- BMAT candidate number
- Centre number
- Date of birth
- Name

Speed as well as accuracy is important in this section. **Work quickly, or you might not finish the paper.** There are no penalties for incorrect responses, only marks for correct answers, so you should attempt **all 27** questions. Each question is worth one mark.

Answer on the sheet provided. Questions ask you to show your choice between options by shading one circle. If you make a mistake, erase thoroughly and try again.

You **must** complete the answer sheet within the time limit.

You can use the question paper for rough working or notes, but **no extra paper** is allowed.

Calculators are NOT permitted.

Please wait to be told you may begin before turning this page.

This question paper consists of 24 printed pages and 4 blank pages.

All questions in this paper assume knowledge that is currently on the BMAT specification.



BLANK PAGE

1 The diagram shows some stages involved in genetic engineering.

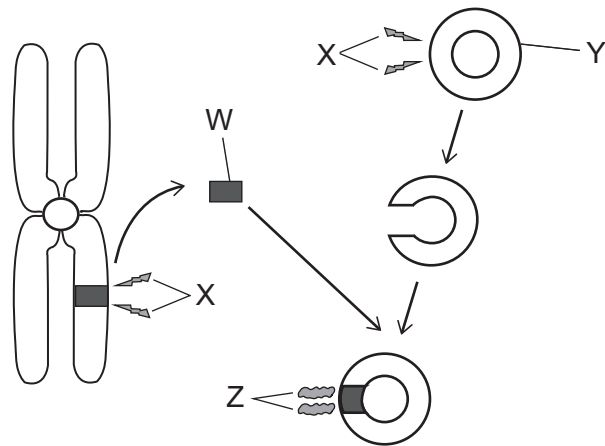

Which row correctly identifies W, X, Y and Z?

	W	X	Y	Z
A	chromosome	restriction enzyme	plasmid	ligase
B	chromosome	ligase	bacterium	restriction enzyme
C	chromosome	restriction enzyme	bacterium	ligase
D	chromosome	ligase	plasmid	restriction enzyme
E	gene	restriction enzyme	plasmid	ligase
F	gene	ligase	bacterium	restriction enzyme
G	gene	restriction enzyme	bacterium	ligase
H	gene	ligase	plasmid	restriction enzyme

- 2** A cleaning solution is used to remove limescale, CaCO_3 , from bathroom surfaces. When the solution is sprayed onto the limescale, effervescence (fizzing) occurs and the solid limescale begins to disappear. This chemical reaction is needed because the limescale cannot be removed with water alone.

Which of the following statements about this chemical reaction are correct?

- 1** The cleaning solution is acidic.
 - 2** The effervescence (fizzing) is caused by the release of hydrogen gas.
 - 3** The pH of the reacting solution will go down as the reaction proceeds.
 - 4** The salt produced in the reaction is more soluble than CaCO_3 .
-
- A** 1 and 2 only
 - B** 1 and 3 only
 - C** 1 and 4 only
 - D** 2 and 3 only
 - E** 2 and 4 only
 - F** 3 and 4 only
 - G** 1, 2 and 3 only
 - H** 2, 3 and 4 only

- 3 The diagram shows the forces acting on a cyclist as she accelerates at 4.0 m s^{-2} on a straight, horizontal section of road. The constant resistive forces are air resistance and a 300 N force due to friction.

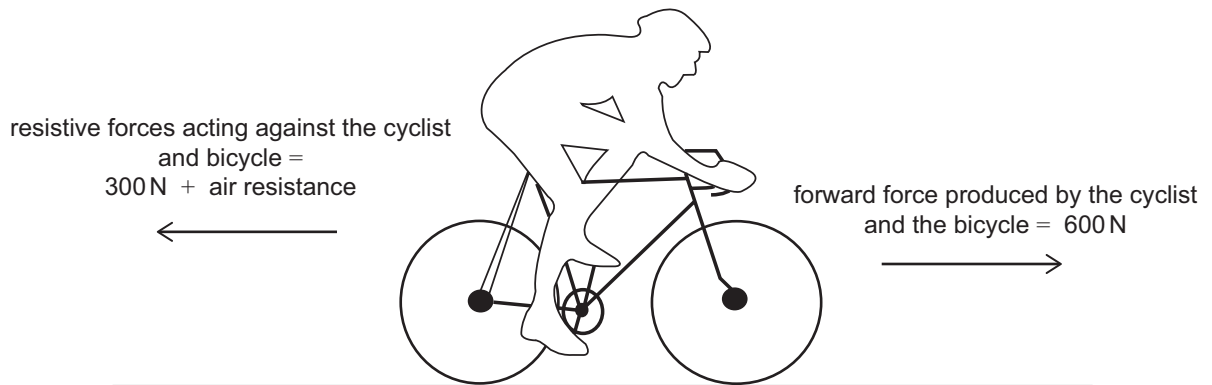

The combined mass of the cyclist and bicycle is 50 kg .

What is the value of the air resistance?

- A 50 N
 - B 100 N
 - C 200 N
 - D 300 N
 - E 450 N
- 4 The non-zero numbers p and q are such that $p + q = 3(p - q)$

What is the value of $\frac{pq}{p^2 + q^2}$

- A $\frac{1}{3}$
- B $\frac{2}{5}$
- C $\frac{1}{2}$
- D $\frac{3}{5}$
- E $\frac{2}{3}$

5 The labels 1, 2 and 3 in the following diagram represent cellular processes.

The shaded areas represent processes that can happen **without** the use of energy provided by cellular respiration.

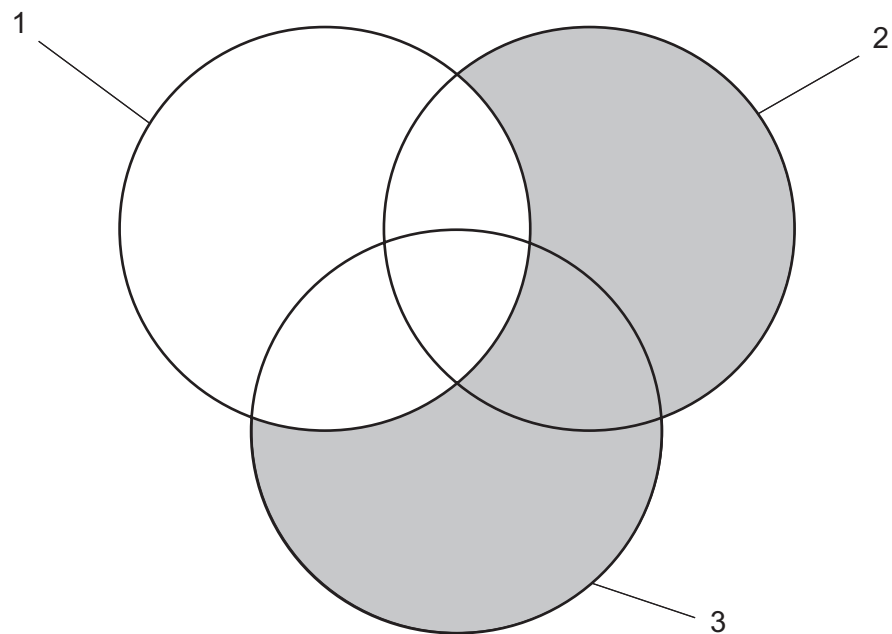

Which processes could labels 1, 2 and 3 represent?

	1	2	3
A	active transport	diffusion	osmosis
B	active transport	diffusion	aerobic respiration
C	diffusion	osmosis	active transport
D	diffusion	aerobic respiration	osmosis
E	osmosis	active transport	aerobic respiration
F	aerobic respiration	active transport	diffusion
G	aerobic respiration	osmosis	active transport

- 6 A chemist used electrolysis to electroplate a pure copper rod with a layer of silver. The concentration of metal ions in the electrolyte was kept constant.

Which row in the table identifies appropriate substances used as the anode (positive electrode), the cathode (negative electrode) and the electrolyte?

	<i>anode</i> <i>(positive electrode)</i>	<i>cathode</i> <i>(negative electrode)</i>	<i>electrolyte</i>
A	pure silver rod	pure copper rod	copper nitrate solution
B	pure copper rod	pure silver rod	copper nitrate solution
C	pure graphite rod	pure silver rod	copper nitrate solution
D	pure silver rod	pure copper rod	silver nitrate solution
E	pure copper rod	pure silver rod	silver nitrate solution
F	pure graphite rod	pure copper rod	silver nitrate solution

- 7 A measuring cylinder resting on an electronic balance contains a liquid as shown in diagram 1. A small solid object X is gently lowered into the liquid and no liquid splashes out of the cylinder. The result is shown in diagram 2.

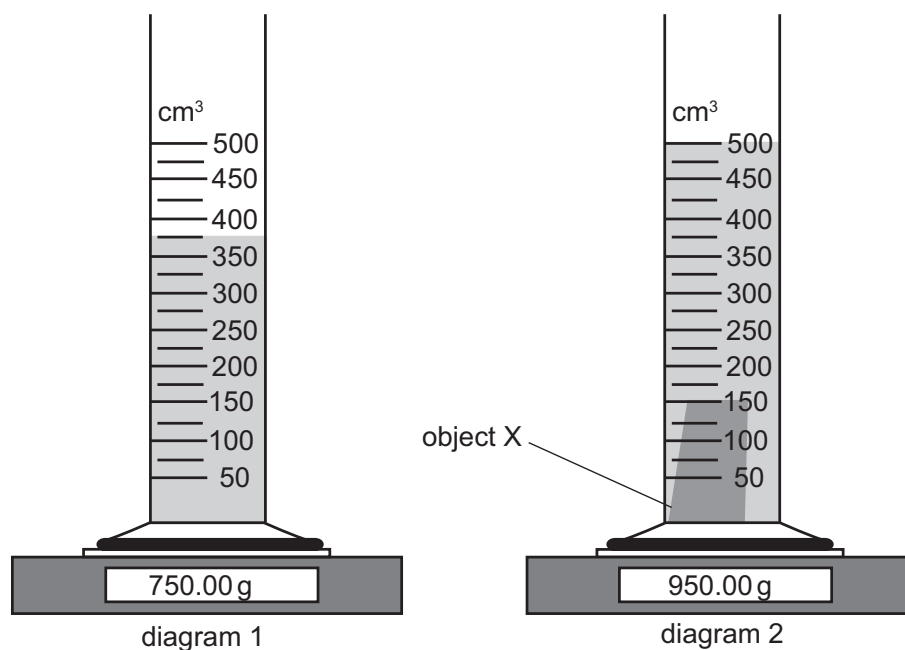

What is the density of the material from which object X is made?

- A 0.40 g cm^{-3}
- B 1.33 g cm^{-3}
- C 1.60 g cm^{-3}
- D 1.90 g cm^{-3}
- E 5.00 g cm^{-3}
- F 6.00 g cm^{-3}
- G 6.33 g cm^{-3}
- H 7.60 g cm^{-3}

8 Find the value of

$$\sqrt{\frac{6 \times 10^2 + 4 \times 10^1}{1.2 \times 10^{-2} + 4 \times 10^{-3}}}$$

- A 2
- B $\sqrt{40}$
- C 20
- D $10\sqrt{40}$
- E 200
- F 2000

- 9 A lizard was placed in a chamber with a constant flow of air. The temperature of the chamber was varied between 25 °C and 10 °C. Apart from temperature and time, all other variables were kept constant.

The carbon dioxide concentrations in the air leaving the chamber are shown in the graph.

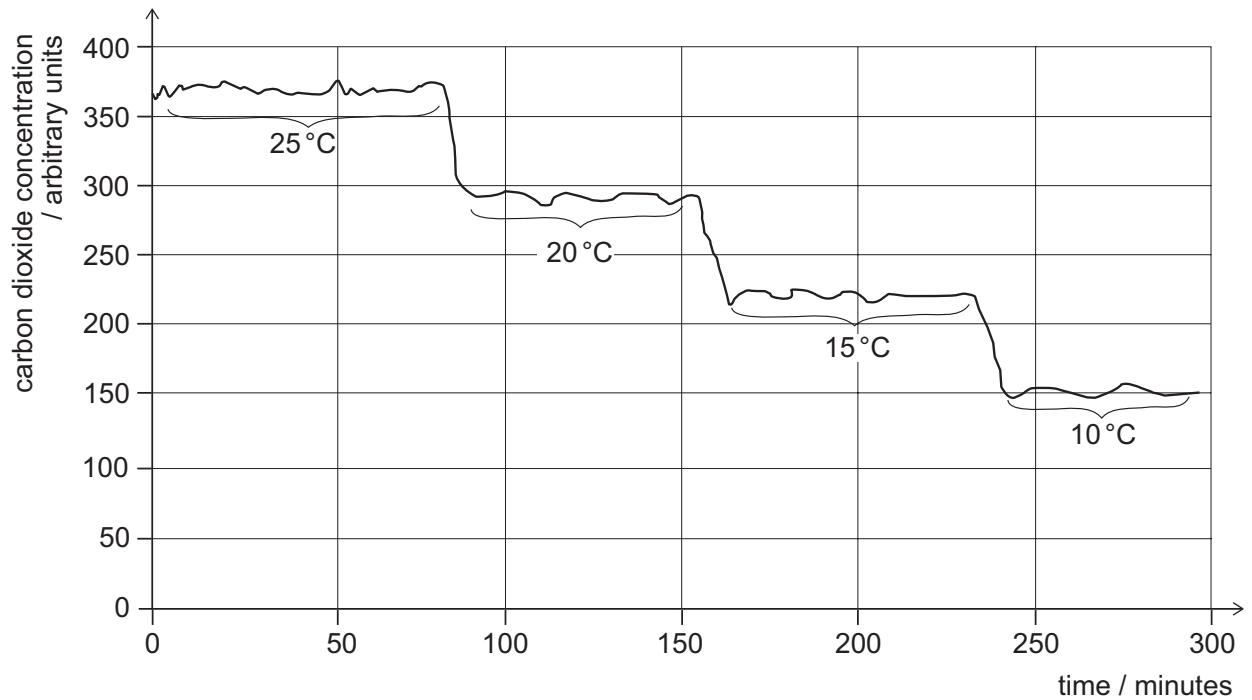

Which of the following statements is/are correct?

- 1 Between 25 °C and 10 °C the respiration rate of the lizard is inversely proportional to the environmental temperature.
 - 2 The data demonstrates that the lizard is only respiring aerobically.
 - 3 The carbon dioxide could be detected by passing the air leaving the chamber through limewater.
- A** none of them
- B** 1 only
- C** 2 only
- D** 3 only
- E** 1 and 2 only
- F** 1 and 3 only
- G** 2 and 3 only
- H** 1, 2 and 3

10 Consider the non-radioactive elements in Group 1.

Which of the following statements is/are correct about the element with the largest atomic number?

- 1** It has the most vigorous reaction with cold water.
 - 2** Its atom has the same number of electrons in its highest occupied energy level as other members of the group.
 - 3** It is the most readily oxidised.
-
- A** none of them
 - B** 1 only
 - C** 2 only
 - D** 3 only
 - E** 1 and 2 only
 - F** 1 and 3 only
 - G** 2 and 3 only
 - H** 1, 2 and 3

- 11 A large metal sphere mounted on an insulating stand is negatively charged. A smaller, uncharged metal sphere mounted on an insulating stand is placed near to the negatively charged sphere.

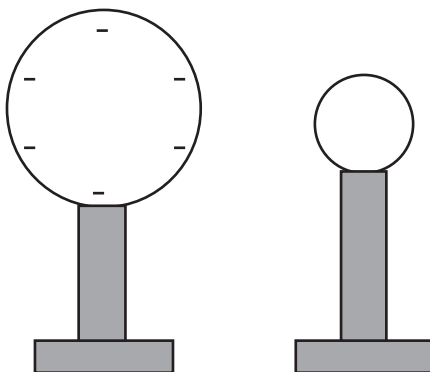

The smaller sphere is connected to the Earth by a conducting wire. Electrons flow from the smaller sphere to Earth because they are repelled by the larger sphere. The smaller sphere is then disconnected from the Earth.

Which row must be correct about the particles in the larger sphere and the final charge of the smaller sphere?

	<i>particles in the larger sphere</i>	<i>final charge of the smaller sphere</i>
A	there are fewer protons than electrons	negative
B	there are fewer protons than electrons	neutral
C	there are fewer protons than electrons	positive
D	there are more protons than electrons	negative
E	there are more protons than electrons	neutral
F	there are more protons than electrons	positive

12 Point M has coordinates $(6, 3p-1)$ and point N has coordinates $(1-p, 2)$.

The gradient of the straight line joining M and N is -3 and it crosses the y -axis at $(0, r)$.

What is the value of r ?

A -11

B -9

C -5

D -1

E 1

F 5

G 9

H 11

13 Which of the following is/are included in the carbon cycle?

1 amino acids in an animal

2 cellulose in a plant cell wall

3 lipids in a bacterial cell membrane

A none of them

B 1 only

C 2 only

D 3 only

E 1 and 2 only

F 1 and 3 only

G 2 and 3 only

H 1, 2 and 3

- 14 The decomposition of hydrogen peroxide in the presence of a manganese(IV) oxide catalyst produces water and oxygen gas.

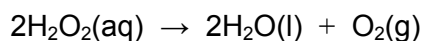

0.2 g of manganese(IV) oxide granules are added to 50 cm³ of 0.1 mol dm⁻³ hydrogen peroxide at 20 °C. The volume of gas collected is shown on the graph as curve X.

A second experiment is carried out at 20 °C using the same mass of manganese(IV) oxide. The volume of gas collected is shown as curve Y.

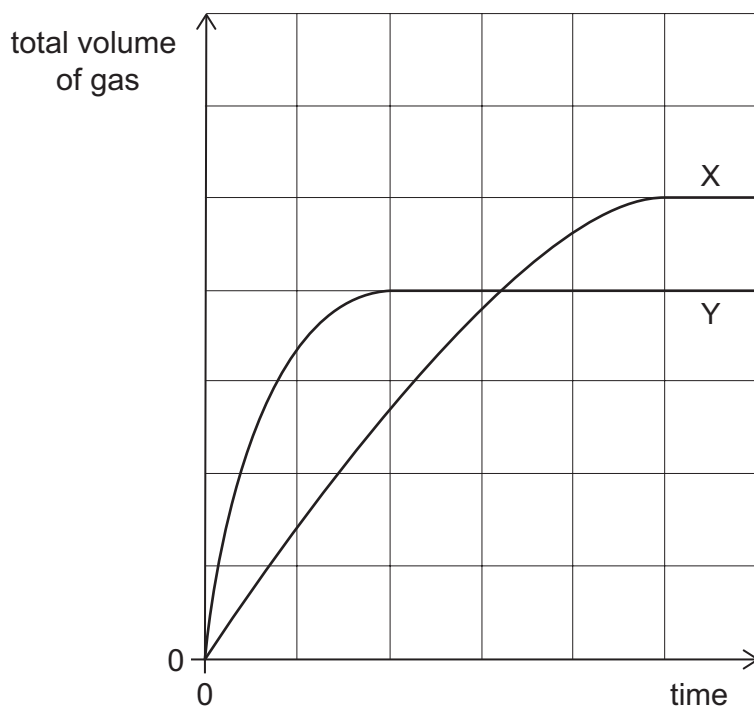

Which of the following conditions could result in curve Y?

	<i>manganese(IV) oxide particle size</i>	<i>volume of hydrogen peroxide / cm³</i>	<i>concentration of hydrogen peroxide / mol dm⁻³</i>
A	powder	20	0.2
B	powder	25	0.2
C	powder	50	0.1
D	granules	20	0.1
E	granules	25	0.2

15 Which statement about waves is correct?

- A All longitudinal waves travel at the same speed.
- B Longitudinal waves cause vibrations perpendicular to the direction of energy transfer.
- C Sound waves are transverse.
- D Transverse waves always travel faster than longitudinal waves.
- E Transverse waves are all electromagnetic.
- F Ultrasonic waves are longitudinal.
- G Ultraviolet waves consist of compressions and rarefactions.
- H X-rays cannot travel in a vacuum.

16 One side of a rectangle is $(7 - \sqrt{5})$ cm.

The rectangle has an area of 66 cm^2 .

What is the perimeter, in cm, of the rectangle?

- A $\frac{35 - 5\sqrt{5}}{2}$
- B $35 - 5\sqrt{5}$
- C $\frac{35 + \sqrt{5}}{2}$
- D $35 + \sqrt{5}$
- E $\frac{105 - 15\sqrt{5}}{2}$
- F $105 - 15\sqrt{5}$
- G $\frac{105 + 7\sqrt{5}}{2}$
- H $105 + 7\sqrt{5}$

- 17 A pea plant is heterozygous for seed colour and homozygous for seed shape.

Yellow seed colour (Y) is dominant to green seed colour (y). Round seed shape (R) is dominant to wrinkled seed shape (r).

Using the information provided, which of the following statements, taken independently, could be correct?

- 1 This plant contains the alleles Y, y, R and r.
 - 2 This plant contains only the alleles Y, y and R.
 - 3 This plant contains only the alleles Y, R and r.
 - 4 The genotype of this plant for seed colour is Yy.
 - 5 The genotype of this plant for seed colour is YY.
 - 6 The genotype of this plant for seed shape is Rr.
 - 7 The genotype of this plant for seed shape is rr.
- A** 1, 4 and 7 only
- B** 1, 5 and 6 only
- C** 2, 4 and 6 only
- D** 2, 4 and 7 only
- E** 2, 5 and 7 only
- F** 3, 4 and 7 only
- G** 3, 5 and 6 only
- H** 3, 5 and 7 only

- 18** The concentration of Fe^{2+} ions in a solution can be determined by titration with acidified potassium manganate(VII) solution.

The ionic equation for the reaction is:

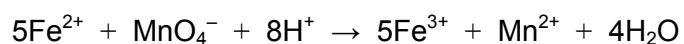

A 25.0 cm^3 sample of solution containing Fe^{2+} ions reacted exactly with 10.0 cm^3 of $0.0500 \text{ mol dm}^{-3}$ potassium manganate(VII) solution.

What is the concentration of Fe^{2+} , in mol dm^{-3} ?

- A** $1.00 \times 10^{-4} \text{ mol dm}^{-3}$
- B** $4.00 \times 10^{-3} \text{ mol dm}^{-3}$
- C** $1.25 \times 10^{-2} \text{ mol dm}^{-3}$
- D** $2.00 \times 10^{-2} \text{ mol dm}^{-3}$
- E** $1.00 \times 10^{-1} \text{ mol dm}^{-3}$
- F** $1.00 \times 10^1 \text{ mol dm}^{-3}$

- 19** Cosmologists have deduced that soon after the Universe was formed it was filled with electromagnetic radiation in the form of intense gamma-rays. They have also deduced that the Universe has been expanding since that time. One effect of this expansion is that the electromagnetic radiation that fills the Universe is now in the microwave region of the spectrum.

Here are three statements about the effects of the Universe expanding on the electromagnetic radiation that filled the early Universe:

- 1** The expansion has caused an increase in the frequency of the radiation.
- 2** The expansion has caused a decrease in the wavelength of the radiation.
- 3** The expansion has caused frequency to change in direct proportion to wavelength.

Which of the statements is/are correct?

- A** none of them
- B** 1 only
- C** 2 only
- D** 3 only
- E** 1 and 2 only
- F** 1 and 3 only
- G** 2 and 3 only
- H** 1, 2 and 3

20 To get to work, Sylvie first catches a bus and then catches a train.

The probability that the bus is on time is 0.6

The probability that the bus is late is 0.4

If the bus is on time, then the probability that she will catch the train is 0.8

If the bus is late, then the probability that she will catch the train is 0.6

Given that Sylvie catches the train, what is the probability that the bus was on time?

A $\frac{1}{3}$

B $\frac{12}{25}$

C $\frac{2}{5}$

D $\frac{3}{5}$

E $\frac{2}{3}$

F $\frac{18}{25}$

G $\frac{6}{7}$

- 21** Which of the following statements is/are correct for a healthy human?
- 1** A protein section coded for by part of a gene consisting of 500 base pairs will have a maximum of 166 amino acids.
 - 2** A liver cell and a mature red blood cell from the same person will both have a chromosome number of 46.
 - 3** The number of adenine bases in an allele must be the same as the number of guanine bases.
- A** none of them
- B** 1 only
- C** 2 only
- D** 3 only
- E** 1 and 2 only
- F** 1 and 3 only
- G** 2 and 3 only
- H** 1, 2 and 3

- 22** Complete combustion of 35 cm^3 of a straight-chain alkane vapour gave 105 cm^3 of carbon dioxide gas. Both gas volumes were measured at the same temperature and pressure.

Which of the following is the molecular formula of the alkane?

- A** C_2H_4
- B** C_2H_6
- C** C_3H_6
- D** C_3H_8
- E** C_4H_{10}

- 23 A water jet pack has lifted a person vertically upwards, as shown in the sketch. He is now stationary at a constant height.

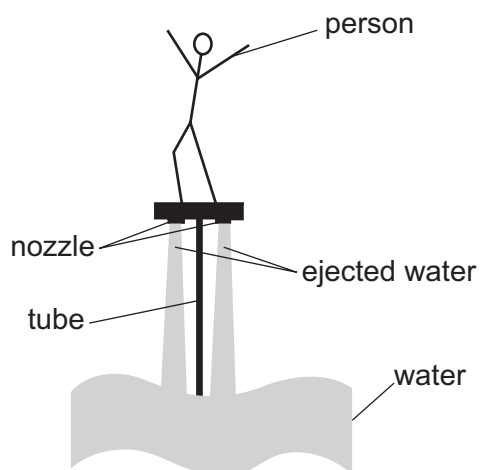

Water rises through the tube and is ejected at a speed of 15 m s^{-1} through two nozzles.

In a time of 12 s, each of the nozzles ejects 400 kg of water vertically downwards.

What is the momentum of the water ejected by **each** nozzle in 12 s, and what is the upward force due to the water ejected by the jet pack?

	<i>momentum / kg m s⁻¹</i>	<i>force / N</i>
A	6000	1000
B	6000	2000
C	12 000	1000
D	12 000	2000
E	45 000	3750
F	45 000	7500
G	90 000	7500
H	90 000	15 000

- 24 A cross-country running track is in the shape of a regular pentagon.

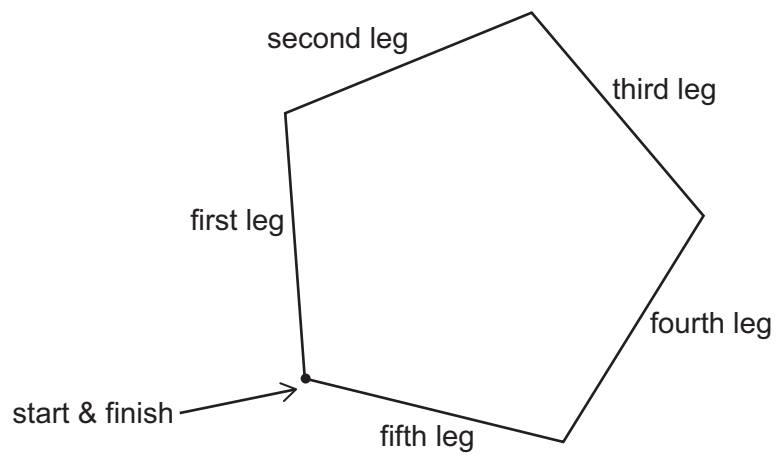

[diagram not to scale]

Competitors run clockwise around the track.

When on the third leg of the course they run on a bearing of 110° .

What bearing do they run on for the first leg?

- A 034°
- B 038°
- C 106°
- D 178°
- E 182°
- F 244°
- G 322°
- H 326°

- 25** A student carried out tests to find out which molecules were present in a sample of urine from a human male. The student recorded the presence of large protein molecules in the urine, and suggested that this indicated that the kidney was not functioning correctly.

Which of the following could have resulted in a high concentration of protein in the urine sample?

- 1** damage to cell membranes between the blood vessels and the Bowman's capsule
 - 2** a reduced rate of active transport and selective re-absorption from the nephron
 - 3** Cells in the collecting duct do not have receptors to bind to antidiuretic hormone (ADH) and so are unable to respond to the hormone.
- A** none of them
- B** 1 only
- C** 2 only
- D** 3 only
- E** 1 and 2 only
- F** 1 and 3 only
- G** 2 and 3 only
- H** 1, 2 and 3

26 Diborane has the formula B_2H_6 .

Assume that boron consists of two isotopes, containing 20% $^{10}_5B$ atoms and 80% $^{11}_5B$ atoms, and that all hydrogen atoms are 1_1H .

Molecules of diborane will therefore have relative masses of 26, 27 or 28.

In what relative proportion will molecules of diborane with masses of 26, 27 and 28 occur?

- A** 1:2:8
- B** 1:2:16
- C** 1:4:8
- D** 1:4:16
- E** 1:8:16
- F** 1:8:64
- G** 1:16:64

- 27 A 100% efficient ideal transformer has 400 turns on its primary coil and 100 turns on its secondary coil. The input voltage across the primary coil is 240 V. An output current of 2.0 A flows in the secondary coil.

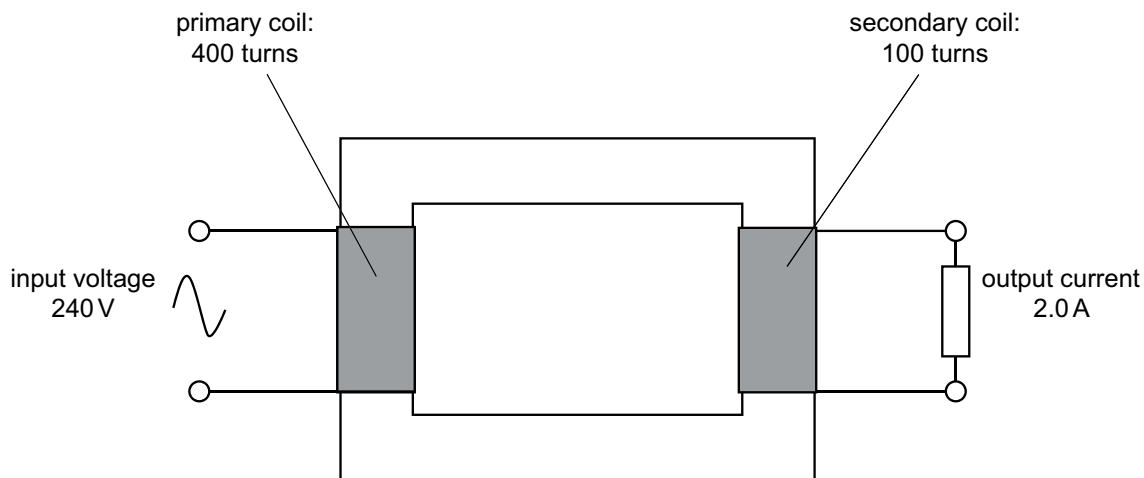

What are the output voltage across the secondary coil, the input current in the primary coil, and the output power of the transformer?

	<i>output voltage / V</i>	<i>input current / A</i>	<i>output power / W</i>
A	60	0.50	30
B	60	0.50	120
C	60	8.0	120
D	60	8.0	480
E	960	0.50	480
F	960	0.50	1920
G	960	8.0	1920
H	960	8.0	7680

END OF TEST

BLANK PAGE

BLANK PAGE

BLANK PAGE